

# 7SG13 Delta

Protection and Control Relays

## Document Release History

This document is issue 2010/02. The list of revisions up to and including this issue is:

Pre release

2010/02	Document reformat due to rebrand
2006/09	"3Vo Input" setting added
2006/01	Modbus Definitions added IEC60870 default definitions revised
2005/12	Connection Diagram and Settings updated Software history revised
2004/7	Updated settings, function diagram and event list
2003/02	v2 Page 9 to 16: corrected various invalid references to other documents
2003/01	First issue

## Software Release History

The list of software revisions applying to the FM1-213, up to the date of this document issue is:

Note: the relay software consists of two parts: Article numbers with the prefix 2471H is the overall configuration this includes the any customer specific mimic/logics, this number can change depending on the configuration.

Article numbers with the prefix 2471S contains the core product functions, this number is common to all FM1-213 relay configurations.

### **FM1-213 Firmware + Default Configuration (2471H80035)**

Mar 2004	R2	Neutral voltage	Minor Change:	See Firmware (2471S81749 R3)
May 2003	R1		First Release	

### **FM1-213 Firmware (2471S81749)**

Mar 2004	R3	Neutral voltage	Minor Change:	Time Multiplier setting range extended.
Dec 2003	R2	General	Additional features:	Measured Earth elements for HS/LS & Idmtl now have the option to be directional.
			Additional features:	Under/Over Frequency added.
			Additional features:	Time & date meters added
May 2003	R1		First release	

The copyright and other intellectual property rights in this document, and in any model or article produced from it (and including any registered or unregistered design rights) are the property of Siemens Protection Devices Ltd. No part of this document shall be reproduced or modified or stored in another form, in any data retrieval system, without the permission Siemens Protection Devices Ltd., nor shall any model or article be reproduced from this document unless Siemens Protection Devices Ltd. consent.

While the information and guidance given in this document is believed to be correct, no liability shall be accepted for any loss or damage caused by any error or omission, whether such error or omission is the result of negligence or any other cause. Any and all such liability is disclaimed.

## Contents

<b>Contents</b> .....	<b>2</b>
<b>List of Figures</b> .....	<b>2</b>
<b>Section 1: Configuration</b> .....	<b>3</b>
1.1 Element Details .....	3
<b>Section 2: Settings</b> .....	<b>5</b>
<b>Section 3: IEC 60870-5-103 Definitions</b> .....	<b>14</b>
<b>Section 4: Modbus Definitions</b> .....	<b>22</b>
<b>Section 5: Application Diagrams</b> .....	<b>25</b>

## List of Figures

Figure 1-1 Functional Diagram for the FM1-213 .....	3
Figure 4-1 Typical Connection Diagram .....	25

## Section 1: Configuration

The connection and interaction of the functions is summarised in Figure 1-1.

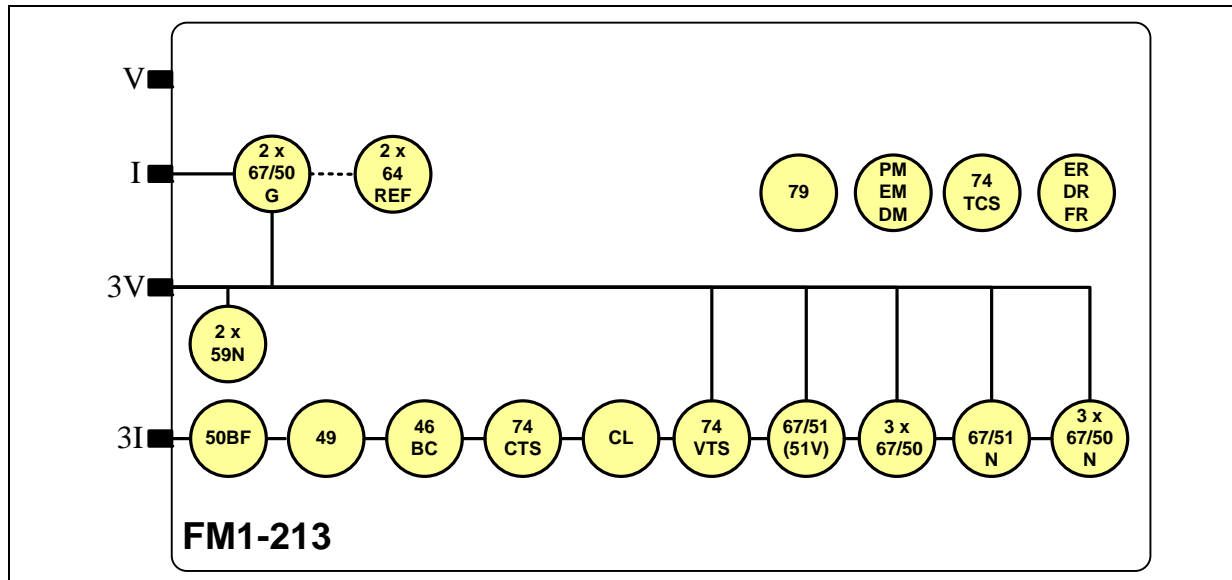

Figure 1-1 Functional Diagram for the FM1-213

### 1.1 Element Details

Details of the protective functions provided in the FM1-213 are given below.

#### OC Shaped Char (51, 51N, 51G)

Element		Technical Reference
P/F	Phase-fault	Current Protections – P20048 section 2.1.1
E/FN	Earth-fault derived	

#### Voltage Controlled OC (51V)

Element		Technical Reference
OC	Voltage Controlled OC	Current Protections – P20048 section 2.1.2

#### OC HS/LS (50, 50N)

Element		Technical Reference
P/F LS	Phase-fault Lowset	Current Protections – P20048 section 2.1.3
P/F HS1	Phase-fault Highset 1	
P/F HS2	Phase-fault Highset 2	
E/FN LS	Earth-fault Lowset	
E/FN HS1	Earth-fault Highset 1	
E/FN HS1	Earth-fault Highset 2	

**SEF/REF (50G, 64REF)**

Element		Technical Reference
SEF	Sensitive Earth Fault	Current Protections – P20048 section 2.1.4
REF	Restricted Earth Fault	

**Thermal Overload (49)**

Element		Technical Reference
O/C	Thermal Overload	Current Protections – P20048 section 2.3.1

**CB Trip Fail (50BF)**

Element		Technical Reference
O/C	Circuit Breaker Failure	Plant Supervision – P20060 section 2.1.1

**Broken Conductor (46BC)**

Element		Technical Reference
O/C	Phase Unbalance	Current Protections - P20048 section 2.5.1

**Cold Load (CL)**

Element		Technical Reference
Control	Cold Load Group Change	Current Protections – P20048 section 2.4.1

**CT Supervision (74CT)**

Element		Technical Reference
O/C	CT Supervision	Plant Supervision – P20060 section 2.2.1

**Neutral Voltage Displacement (59N)**

Element		Technical Reference
3V0-1	Neutral Voltage Displacement 1	Voltage Protections – P20051 section 2.1.3
3V0-1	Neutral Voltage Displacement 2	

**VT Supervision (74VT)**

Element		Technical Reference
VTS	VT Supervision	Plant Supervision – P20060 section 2.2.2

**Trip Cct Supervision (74TC)**

Element		Technical Reference
TCS	Trip Circuit Supervision	Plant Supervision – P20060 section 2.3.1

**Directional (67, 67N, 67G)**

Element		Technical Reference
P/F	Phase Fault	Current Protections – P20048 section 2.2.1 and 2.2.2
E/F	Earth Fault Derived	
SEF	Sensitive Earth Fault	

**Autoreclose (79)**

Element		Technical Reference
Control	Autoreclose	Autoreclosing – P20064 section 2.1

## Section 2: Settings

Relay Type \_\_\_\_\_

Serial Number \_\_\_\_\_

Substation \_\_\_\_\_

Feeder Identity \_\_\_\_\_

### Notes on Tables

The second column in the tables ('Ref') provides a reference to the section in the appropriate Technical Reference publication (listed immediately above the table) that describes the setting.

The third column is left blank to allow users to complete the table with applied settings.

### System Config. Menu

Ref: P20025 Common Features

Setting name	Ref	Applied value
Active Group	2.2.1	
View/Edit Group	2.2.1	
Phase Input	2.2.2.1	A
Phase CT Ratio	2.2.2.1	
Aux Input	2.2.2.1	
Aux CT Ratio	2.2.2.1	
Earth Fault Mode	2.2.2.1	
Phase VT Ratio	2.2.2.2	
Voltage Config	2.2.2.2	
Sett Grp Select	2.2.1.1	
Clock Sync. From Status	2.2.4	
Backlight timer	2.2.5	min
Default Screens Timer	2.2.6	min
Date	2.2.4	
Time	2.2.4	
Change Password	2.2.7	
Relay Identifier	2.2.8	

### Protection : OC Shaped Char

Ref: P20048 Current Protections

Setting name	Ref	Applied value
P/F Shaped Char	2.1.1	
P/F Char Dir		
P/F Char Setting		xIn
P/F Charact		
P/F Multiplier		
P/F Char Delay		s

Setting name	Ref	Applied value
P/F Reset(ANSI)		
P/F Reset Delay		
E/F Shaped Char	2.1.1	
E/F Char Dir		
E/F Char Setting		xIn
E/F Charact		
E/F Multiplier		
E/F Char Delay		s
E/F Reset(ANSI)		
E/F Reset Delay		s

### Protection: V Controlled OC

Ref: P20048 Current Protections

Setting name	Ref	Applied value
VCO Enable	2.1.2	
VCO Level		V
VCO Multiplier		
VT Fail Inhibit		

### Protection : OC HS/LS

Ref: P20048 Current Protections

Setting name	Ref	Applied value
P/F LS	2.1.3	
P/F LS Dir		
P/F LS Setting		xIn
P/F LS Delay		s
P/F HS1	2.1.3	
P/F HS1 Dir		
P/F HS1 Setting		xIn
P/F HS1 Delay		s

Setting name	Ref	Applied value
P/F HS2	2.1.3	
P/F HS2 Dir		
P/F HS2 Setting		xIn
P/F HS2 Delay		s
E/F LS	2.1.3	
E/F LS Dir		
E/F LS Setting		xIn
E/F LS Delay		s
E/F HS1	2.1.3	
E/F HS1 Dir		
E/F HS1 Setting		xIn
E/F HS1 Delay		s
E/F HS2	2.1.3	
E/F HS2 Dir		
E/F HS2 Setting		xIn
E/F HS2 Delay		s

**Protection : SEF/REF**

Ref: P20048 Current Protections

Setting name	Ref	Applied value
Sef 1	2.1.4	
Sef 1 Dir		
Sef 1 Setting		xIn
Sef 1 Timer		s
Sef 1 Reset Char		
Sef 1 Reset Delay		
Sef 2	2.1.4	
Sef 2 Dir		
Sef 2 Setting		xIn
Sef 2 Timer		s
Sef 2 Reset Char		
Sef 2 Reset Delay		
Ref 1	2.1.4	
Ref 1 Setting		xIn
Ref 1 Timer		s
Ref 1 Reset Char		
Ref 1 Reset Delay		
Ref 2	2.1.4	
Ref 2 Setting		xIn
Ref 2 Timer		s

Setting name	Ref	Applied value
Ref 2 Reset Char		
Ref 2 Reset Delay		

**Protection : Thermal Overload**

Ref: P20048 Current Protections

Setting name	Ref	Applied value
Thermal Overload	2.3.1	
Overload Setting		xIn
Time Constant		min
Hot/Cold Ratio		
Capacity Alarm		
Load Inc Alarm		
Overload Alarm		
Reset Ther State		

**Protection : Cold Load**

Ref: P20048 Current Protections

Setting name	Ref	Applied value
Cold Load	2.4	
Cold Load Group		
Pick-up Time		s
Drop-off Time		s
Reduced Current		
Reduced Cur Time		s

**Protection : Broken Conductor**

Ref: P20048 Current Protections

Setting name	Ref	Applied value
Broken Conductor	2.5	
Trip Enable		
Failure Time		ms
Current Threshld		xIn

**Protection: Voltage Protection**

Ref: P20051 Neutral Voltage

Setting name	Ref	Applied value
3Vo Input	2.1.3	
3Vo-1 Charact	2.1.3	
3Vo-1 Dir		
3Vo-1 Setting		V
3Vo-1 Delay		s
3Vo-1 Multiplier		

Setting name	Ref	Applied value
3Vo-1 Reset Delay		s
3Vo-2 Charact	2.1.3	
3Vo-2 Dir		
3Vo-2 Setting		V
3Vo-2 Delay		s
3Vo-2 Multiplier		
3Vo-2 Reset Delay		s

**Directional**

Ref: P20048 Current Protections

Setting name	Ref	Applied value
2-out-of-3 Logic	2.2.1.1	
P/F Char Angle		deg
E/F Char Angle		deg
SEF Char Angle		deg

**Protection : CB Trip Fail**

Ref: P20060 Plant Supervision

Setting name	Ref	Applied value
Trip Fail Time 1	2.1.1	s
Trip Fail Time 2		s
Trip Fail Level		

**Protection : CT Supervision**

Ref: P20060 Plant Supervision

Setting name	Ref	Applied value
CT Supervision	2.2.1	
CT Failure Time		ms
Current Threshld		xIn

**Protection : VT Supervision**

Ref: P20060 Plant Supervision

Setting name	Ref	Applied value
VT Supervision	2.2.2	
VTS PF Inhibit		
VTS Inps Level		xIn
VTS Vnps Level		V
VTS Mode		

**Protection : Trip Cct Super**

Ref: P20060 Plant Supervision

Setting name	Ref	Applied value
Trip Cct Super	2.3.1	

**Autoreclose**

Ref: P20064 Autoreclosing

Setting name	Ref	Applied value
A/R In Service	2.1	
Number Of Shots		
First Deadtime		s
Second Deadtime		s
Third Deadtime		s
Fourth Deadtime		s
CB Close Pulse		s
Reclaim Time		s
Prot Trip 1		
Prot Trip 2		
Prot Trip 3		
Prot Trip 4		
Line Check Trip		
HS1 TTL		
HS2 TTL		
Rec Block Delay		s
Slow Open Delay	ms	
Seq Fail Timer		
Min LO Timer	s	
Reset LO By Time		

**Output Relays : O/P Relay Config**

Ref: P20025 Common Features

Setting name	Ref	Applied value
Prot Healthy	2.3	
General Trip		
General Starter		
PhaseATrip		
PhaseBTrip		
PhaseCTrip		
EarthTrip		
P/F Starter		
P/F Charact		
E/F Starter		
E/F Charact		
P/F LS		
P/F HS1		
P/F HS2		

Setting name	Ref	Applied value
E/F LS		
E/F HS1		
E/F HS2		
SEF/REF 1 Trip		
SEF/REF 2 Trip		
Thermal OL Trip		
Therm Cap Alarm		
Load Incr Alarm		
Thermal OL Alarm		
Cold Load Active		
Cold Load Trip		
BrokenConductor		
BrokenCondTrip		
PhaseAFwd		
PhaseARev		
PhaseBFwd		
PhaseBRev		
PhaseCFwd		
PhaseCRev		
EarthFwd		
EarthRev		
Sef Fwd		
Sef Rev		
3V0 Starter		
3V0-1 Trip		
3V0-2 Trip		
CB Fail 1		
CB Fail 2		
CTFailed		
VTFailed		
Trip Cct Failed		
Lockout		
A/R Switched Out		
A/R In Progress		
Successful Close		
Line Check		
Ext Arc Start		
OpsCountAlarm		
DeltaCountAlarm		

Setting name	Ref	Applied value
I <sup>2</sup> t Count Alarm		
CBFailedToOpen		
CBFailedToClose		
CBInvalid		
CBOpen		
CBClosed		
GeneralClose		
ControlTrip		
O/P Relay Test		
Status 1		
Status 2		
Status 3		
Status 4		
Status 5		
Status 6		
Status 7		
Status 8		
Status 9		
Status 10		
Status 11		
Status 12		
Status 13		
Status 14		
Status 15		
Status 16		
Status 17		
Status 18		
Status 19		
Status 20		
Status 21		
Status 22		
Status 23		
Status 24		
Status 25		
Status 26		
Status 27		
Hand Rst Outputs		



**Output Relays : O/P Min Op Timers**

Ref: P20025 Common Features

Setting name	Ref	Applied value
Min Op Time 1	2.3	s
Min Op Time 2		s
Min Op Time 3		s
Min Op Time 4		s
Min Op Time 5		s
Min Op Time 6		s
Min Op Time 7		s
Min Op Time 8		s
Min Op Time 9		s
Min Op Time 10		s
Min Op Time 11		s
Min Op Time 12		s
Min Op Time 13		s

**Status Inputs**

Ref: P20025 Common Features

Setting name	Ref	Applied value
Invert Inputs	2.3	

**Status Inputs : Status Config**

Ref: P20025 Common Features

Setting name	Ref	Applied value
P/F Char Inhibit	2.3	
E/F Char Inhibit		
P/F LS Inhibit		
P/F HS1 Inhibit		
P/F HS2 Inhibit		
E/F LS Inhibit		
E/F HS1 Inhibit		
E/F HS2 Inhibit		
SEF/REF 1 Inhibit		
SEF/REF 2 Inhibit		
P/F Dir Inhibit		
E/F Dir Inhibit		
SEF Dir Inhibit		
3V0-1 Inhibit		
3V0-2 Inhibit		
Trip Fail Start		
Trip Cct Fail		

Setting name	Ref	Applied value	
Starter			
A/R In			
A/R Out			
Extern A/R Start			
Block Reclose			
Go To Lockout			
Trip And Reclose			
Trip and Lockout			
Reset Lockout			
Manual Close			
I <sup>2</sup> t Cnt Update			
CBAClosed			
CBBClosed			
CBCClosed			
CBAOpen			
CBBOpen			
CBCOpen			
Waveform Trig			
Select Sett Grp			
Inhibit Sel Grp			
Reset Flag_O/P			
Clock Sync.			

**Status Inputs : I/P PU Timers**

Ref: P20025 Common Features

Setting name	Ref	Applied value
I/P PU Time 1	2.3	s
I/P PU Time 2		s
I/P PU Time 3		s
I/P PU Time 4		s
I/P PU Time 5		s
I/P PU Time 6		s
I/P PU Time 7		s
I/P PU Time 8		s
I/P PU Time 9		s
I/P PU Time 10		s
I/P PU Time 11		s
I/P PU Time 12		s
I/P PU Time 13		s
I/P PU Time 14		s

Setting name	Ref	Applied value
I/P PU Time 15		s
I/P PU Time 16		s
I/P PU Time 17		s
I/P PU Time 18		s
I/P PU Time 19		s
I/P PU Time 20		s
I/P PU Time 21		s
I/P PU Time 22		s
I/P PU Time 23		s
I/P PU Time 24		s
I/P PU Time 25		s
I/P PU Time 26		s
I/P PU Time 27		s

**Status Inputs : I/P DO Timers**

Ref: P20025 Common Features

Setting name	Ref	Applied value
I/P DO Time 1		s
I/P DO Time 2		s
I/P DO Time 3		s
I/P DO Time 4		s
I/P DO Time 5		s
I/P DO Time 6		s
I/P DO Time 7		s
I/P DO Time 8		s
I/P DO Time 9		s
I/P DO Time 10		s
I/P DO Time 11		s
I/P DO Time 12		s
I/P DO Time 13		s
I/P DO Time 14		s
I/P DO Time 15		s
I/P DO Time 16		s
I/P DO Time 17		s
I/P DO Time 18		s
I/P DO Time 19		s
I/P DO Time 20		s
I/P DO Time 21		s
I/P DO Time 22		s
I/P DO Time 23		s

Setting name	Ref	Applied value
I/P DO Time 24		s
I/P DO Time 25		s
I/P DO Time 26		s
I/P DO Time 27		s

**LEDs : LED Config**

Ref: P20025 Common Features

Setting name	Ref	Applied value
GeneralTrip	2.3	
GeneralStarter		
PhaseATrip		
PhaseBTrip		
PhaseCTrip		
EarthTrip		
P/F Starter		
P/F Charact		
E/F Starter		
E/F Charact		
P/F LS		
P/F HS1		
P/F HS2		
E/F LS		
E/F HS1		
E/F HS2		
SEF/REF 1 Trip		
SEF/REF 2 Trip		
Thermal OL Trip		
Therm Cap Alarm		
Load Incr Alarm		
Thermal OL Alarm		
Cold Load Active		
Cold Load Trip		
BrokenConductor		
BrokenCondTrip		
PhaseAFwd		
PhaseARev		
PhaseBFwd		
PhaseBRev		
PhaseCFwd		
PhaseCRev		

Setting name	Ref	Applied value
EarthFwd		
EarthRev		
SEF Fwd		
SEF Rev		
3V0-1 Starter		
3V0-1 Trip		
3V0-2 Trip		
CB Fail 1		
CB Fail 2		
CTFailed		
VTFailed		
Trip Cct Failed		
Lockout		
A/R Switched Out		
A/R In Progress		
Successful Close		
Line Check		
Ext Arc Start		
OpsCountAlarm		
DeltaCountAlarm		
I <sup>2</sup> t Count Alarm		
CBFailedToOpen		
CBFailedToClose		
CBInvalid		
CBOpen		
CBClosed		
GeneralClose		
ControlTrip		
O/P Relay Test		
Status 1		
Status 2		
Status 3		
Status 4		
Status 5		
Status 6		
Status 7		
Status 8		
Status 9		
Status 10		

Setting name	Ref	Applied value
Status 11		
Status 12		
Status 13		
Status 14		
Status 15		
Status 16		
Status 17		
Status 18		
Status 19		
Status 20		
Status 21		
Status 22		
Status 23		
Status 24		
Status 25		
Status 26		
Status 27		
Self Reset LEDs		

**LEDs : LED Labels**

Ref: P20025 Common Features

Setting name	Ref	Applied value
Led1 Label	2.3	
Led2 Label		
Led3 Label		
Led4 Label		
Led5 Label		
Led6 Label		
Led7 Label		
Led8 Label		
Led9 Label		
Led10 Label		
Led11 Label		
Led12 Label		
Led13 Label		
Led14 Label		
Led15 Label		
Led16 Label		
Led17 Label		
Led18 Label		

Setting name	Ref	Applied value
Led19 Label		
Led20 Label		
Led21 Label		
Led22 Label		
Led23 Label		
Led24 Label		
Led25 Label		
Led26 Label		
Led27 Label		
Led28 Label		
Led29 Label		
Led30 Label		
Led31 Label		
Led32 Label		

**ReyLogiC** : ReyLogiC Control

Setting name	Ref	Applied value
IO Booleans		
General Logic		
Control Logic		
ARC/Fault Trig		

**ReyLogiC** : ReyLogiC Elements

Setting name	Ref	Applied value
Control Close		ms

**Comms Interface**: Comms Interface

Ref: P20025 Common Features

Setting name	Ref	Applied value
Station Address	3.3	
IEC 870 on Port		
Line Switch Time		
Com 1 Baud Rate		
Com 1 Parity		
Com 1 Line Idle		
Com 1 Data Echo		
Com 2 Baud Rate		
Com 2 Parity		
Com 2 Line Idle		
Com 2 Data Echo		
Com 2 Direction		

Setting name	Ref	Applied value
IEC 870 update		

**Comms Interface** : IEC870 Update

Ref: P20025 Common Features

Setting name	Ref	Applied value
Measurand Type	3.3.9	
Class2 Refresh		s
Curr High Update		%
Curr Low Update		%
Volt High Update		%
Volt Low Update		%
Watt High Update		%
Watt Low Update		%
Vars High Update		%
Vars Low Update		%
Freq High Update		%
Freq Low Update		%
Sync Angle High		%
Sync Angle Low		%

**Data Storage**

Ref: P20025 Common Features

Setting name	Ref	Applied value
Pre-trigger Storage	2.5	%
Record Duration		s
Trigger Waveform		
Clear Waveforms		
Clear Events		
Clear Faults		
Reset Demand		
Reset WHr Met		
Reset Varhr Met		
Energy Ev Level		W
Energy Ev Time		s

**CB Maintenance** : Trip Counter

Ref: P20025 Common Features

Setting name	Ref	Applied value
Trip Count Alarm	2.6	
Delta Trip Alarm		
Reset Trip Cnt		

Setting name	Ref	Applied value
Reset Delta Cnt		

**CB Maintenance : I<sup>2</sup>t CB Wear**

Ref: P20025 Common Features

Setting name	Ref	Applied value
I <sup>2</sup> t Counter	2.6	
Alarm Limit		MA <sup>2</sup> s
Separation Time		s
Clearance Time		s
Reset I <sup>2</sup> t Count		

**Maintenance : IO Test**

Ref: P20025 Common Features

Setting name	Ref	Applied value
Test O/P Relays	2.6	

**Mimic Settings**

Ref: P20025 Common Features

Setting name	Ref	Applied value
Circuit Breaker1		

## Section 3: IEC 60870-5-103 Definitions

### Cause of Transmission

The cause of transmission (COT) column of the 'Information Number and Function' table lists possible causes of transmission for these frames. The following abbreviations are used:

Abbreviation	Description
SE	spontaneous event
T	test mode
GI	general interrogation
Loc	local operation
Rem	remote operation
Ack	command acknowledge
Nak	Negative command acknowledge

Note: Events listing a GI cause of transmission can be raised and cleared; other events are raised only.

### Function Type

Abbreviation	Description
1	Time tagged message (monitor direction)
2	Time tagged message (relative time) (monitor direction)
3.1	Measurands I
4	Time-tagged measurands with relative time
5	Identification message
6	Time synchronisation
20	General command

### Information Number and Function

The following table lists information number and function definitions together with a description of the message and function type and cause of transmission that can result in that message. Not all definitions are available on all relay types – this is dependent on functionality.

Function	Information Number	Description	Function Type	Cause of Transmission
60	1	IEC870 Active Com1	1	SE, GI,
60	2	IEC870 Active Com2	1	SE, GI,
60	3	Front Port OverRide	1	SE, GI,
60	135	Trigger Storage	1	SE
60	136	Clear Waveform Records	1	SE
60	137	Clear Fault Records	1	SE
60	138	Clear Event Records	1	SE
70	5	Status Input 5	1	SE, GI,
70	6	Status Input 6	1	SE, GI,
70	7	Status Input 7	1	SE, GI,
70	8	Status Input 8	1	SE, GI,
70	9	Status Input 9	1	SE, GI,
70	10	Status Input 10	1	SE, GI,
70	11	Status Input 11	1	SE, GI,
70	12	Status Input 12	1	SE, GI,
70	13	Status Input 13	1	SE, GI,
70	14	Status Input 14	1	SE, GI,
70	15	Status Input 15	1	SE, GI,

Function	Information Number	Description	Function Type	Cause of Transmission
70	16	Status Input 16	1	SE, GI,
70	17	Status Input 17	1	SE, GI,
70	18	Status Input 18	1	SE, GI,
70	19	Status Input 19	1	SE, GI,
70	20	Status Input 20	1	SE, GI,
70	21	Status Input 21	1	SE, GI,
70	22	Status Input 22	1	SE, GI,
70	23	Status Input 23	1	SE, GI,
70	24	Status Input 24	1	SE, GI,
70	25	Status Input 25	1	SE, GI,
70	26	Status Input 26	1	SE, GI,
70	27	Status Input 27	1	SE, GI,
70	28	Status Input 28	1	SE, GI,
70	29	Status Input 29	1	SE, GI,
70	30	Status Input 30	1	SE, GI,
70	31	Status Input 31	1	SE, GI,
70	32	Status Input 32	1	SE, GI,
80	1	Plant Control Relay 1	1	SE, GI,
80	2	Plant Control Relay 2	1	SE, GI,
80	3	Plant Control Relay 3	1	SE, GI,
80	4	Plant Control Relay 4	1	SE, GI,
80	5	Plant Control Relay 5	1	SE, GI,
80	6	Plant Control Relay 6	1	SE, GI,
80	7	Plant Control Relay 7	1	SE, GI,
80	8	Plant Control Relay 8	1	SE, GI,
80	9	Plant Control Relay 9	1	SE, GI,
80	10	Plant Control Relay 10	1	SE, GI,
80	11	Plant Control Relay 11	1	SE, GI,
80	12	Plant Control Relay 12	1	SE, GI,
80	13	Plant Control Relay 13	1	SE, GI,
80	14	Plant Control Relay 14	1	SE, GI,
80	15	Plant Control Relay 15	1	SE, GI,
80	16	Plant Control Relay 16	1	SE, GI,
80	17	Plant Control Relay 17	1	SE, GI,
80	18	Plant Control Relay 18	1	SE, GI,
80	19	Plant Control Relay 19	1	SE, GI,
80	20	Plant Control Relay 20	1	SE, GI,
80	21	Plant Control Relay 21	1	SE, GI,
80	22	Plant Control Relay 22	1	SE, GI,
80	23	Plant Control Relay 23	1	SE, GI,
80	24	Plant Control Relay 24	1	SE, GI,
80	25	Plant Control Relay 25	1	SE, GI,
80	26	Plant Control Relay 26	1	SE, GI,
80	27	Plant Control Relay 27	1	SE, GI,
80	28	Plant Control Relay 28	1	SE, GI,
80	29	Plant Control Relay 29	1	SE, GI,
80	30	Plant Control Relay 30	1	SE, GI,
80	31	Plant Control Relay 31	1	SE, GI,
80	32	Plant Control Relay 32	1	SE, GI,
160	2	Reset FCB	5	Reset FCB

Function	Information Number	Description	Function Type	Cause of Transmission
160	3	Reset CU	5	Reset CU
160	4	Start/Restart	5	Start/Restart
160	5	Power On	1	SE
160	16	Auto-reclose active (In/Out)	1	SE, GI
			20	Ack, Nak
160	19	LEDs reset (Reset Flag & Outputs)	1	SE, GI
			20	Ack, Nak
160	21	Trip Test	1	SE
160	22	Settings changed	1	SE
160	23	Settings Group 1 Select	1	SE, GI
			20	Ack, Nak
160	24	Settings Group 2 Select	1	SE, GI
			20	Ack, Nak
160	25	Settings Group 3 Select	1	SE, GI
			20	Ack, Nak
160	26	Settings Group 4 Select	1	SE, GI
			20	Ack, Nak
160	27	Status Input 1	1	SE, GI
160	28	Status Input 2	1	SE, GI
160	29	Status Input 3	1	SE, GI
160	30	Status Input 4	1	SE, GI
160	36	Trip circuit fail	1	SE, GI
160	46	Group Warning	1	SE, GI
160	47	Alarm	1	SE, GI
160	64	A-Delayed Starter	2	SE, GI
160	65	B-Delayed Starter	2	SE, GI
160	66	C-Delayed Starter	2	SE, GI
160	67	E-Delayed Starter	2	SE, GI
160	68	General Trip	2	SE
160	69	A-general trip	2	SE
160	70	B-general trip	2	SE
160	71	C-general trip	2	SE
160	84	General Starter	2	SE
160	85	Circuit breaker fail 1	2	SE
160	91	P/F-general HS trip	2	SE
160	92	E/F-general trip	2	SE
160	93	E/F-general HS trip	2	SE
160	128	CB on by auto reclose	1	SE
160	130	Reclose blocked	1	SE
168	0	Data lost	1	SE
168	1	A-lowset starter	2	SE
168	2	B-lowset starter	2	SE
168	3	C-lowset starter	2	SE
168	4	E-lowset starter	2	SE
168	5	A-lowset trip	2	SE
168	6	B-lowset trip	2	SE
168	7	C-lowset trip	2	SE
168	8	E-lowset trip	2	SE
168	9	A-Delayed Trip	2	SE
168	10	B-Delayed Trip	2	SE



Function	Information Number	Description	Function Type	Cause of Transmission
168	11	C-Delayed Trip	2	SE
168	12	E-Delayed Trip	2	SE
168	13	A-HS1 trip	2	SE
168	14	B-HS1 trip	2	SE
168	15	C-HS1 trip	2	SE
168	16	E-HS1 trip	2	SE
168	17	A-HS2 trip	2	SE
168	18	B-HS2 trip	2	SE
168	19	C-HS2 trip	2	SE
168	20	E-HS2 trip	2	SE
168	21	SEF/REF starter1	2	SE
168	22	SEF/REF starter2	2	SE
168	24	SEF/REF trip1	2	SE
168	25	SEF/REF trip2	2	SE
168	26	A-HS1 starter	2	SE
168	27	B-HS1 starter	2	SE
168	28	C-HS1 starter	2	SE
168	29	E-HS1 starter	2	SE
168	30	A-HS2 starter	2	SE
168	31	B-HS2 starter	2	SE
168	32	C-HS2 starter	2	SE
168	33	E-HS2 starter	2	SE
168	34	CB Opened	1	SE
<b>168</b>	<b>39</b>	<b>Circuit breaker fail 2</b>	<b>2</b>	<b>SE</b>
<b>168</b>	<b>40</b>	<b>MeasE/F-general trip</b>	<b>2</b>	<b>SE</b>
<b>168</b>	<b>41</b>	<b>CB Close Fail</b>	<b>1</b>	<b>SE, GI</b>
<b>168</b>	<b>43</b>	<b>CB DBI state</b>	<b>1</b>	<b>SE, GI</b>
<b>168</b>	<b>44</b>	<b>A-Forward</b>	<b>2</b>	<b>SE, GI</b>
<b>168</b>	<b>45</b>	<b>A-Reverse</b>	<b>2</b>	<b>SE, GI</b>
<b>168</b>	<b>46</b>	<b>B-Forward</b>	<b>2</b>	<b>SE, GI</b>
<b>168</b>	<b>47</b>	<b>B-Reverse</b>	<b>2</b>	<b>SE, GI</b>
<b>168</b>	<b>48</b>	<b>C-Forward</b>	<b>2</b>	<b>SE, GI</b>
<b>168</b>	<b>49</b>	<b>C-Reverse</b>	<b>2</b>	<b>SE, GI</b>
<b>168</b>	<b>50</b>	<b>E/F-Forward</b>	<b>2</b>	<b>SE, GI</b>
<b>168</b>	<b>51</b>	<b>E/F-Reverse</b>	<b>2</b>	<b>SE, GI</b>
168	52	V Element 1 Starter	2	SE, GI
168	53	V Element 2 Starter	2	SE, GI
168	54	V Element 3 Starter	2	SE, GI
168	55	V Element 4 Starter	2	SE, GI
168	56	V Element 1 Trip	2	SE, GI
168	57	V Element 2 Trip	2	SE, GI
168	58	V Element 3 Trip	2	SE, GI
168	59	V Element 4 Trip	2	SE, GI
168	60	SEF-Forward	2	SE, GI
168	61	SEF-Reverse	2	SE, GI
168	62	I2 Element 1 starter	2	SE, GI
168	63	I2 Element 2 starter	2	SE, GI
168	65	I2 Element 1 trip	2	SE, GI
168	66	I2 Element 2 trip	2	SE, GI
168	68	I2 general trip	2	SE, GI

Function	Information Number	Description	Function Type	Cause of Transmission
168	69	Group Switched - External	1	SE, GI
168	70	Trip count alarm	1	SE, GI
<b>168</b>	<b>71</b>	<b>CB maintenance alarm</b>	<b>1</b>	<b>SE, GI</b>
168	73	Delta Trip count alarm	1	SE, GI
168	74	Trip count overflowed	1	SE, GI
168	75	Delta count overflowed	1	SE, GI
168	76	A Broken Conductor	1	SE, GI
168	77	B Broken Conductor	1	SE, GI
168	78	C Broken Conductor	1	SE, GI
<b>168</b>	<b>79</b>	<b>Broken Conductor</b>	<b>1</b>	<b>SE, GI</b>
168	80	Waveform stored	1	SE, GI
168	82	Trip And Lockout	1	SE, GI
168	84	Trip And Reclose	1	SE, GI
168	85	Circuit breaker closed	1	SE, GI
<b>168</b>	<b>88</b>	<b>Reclaim</b>	<b>1</b>	<b>SE, GI</b>
<b>168</b>	<b>89</b>	<b>Lockout</b>	<b>1</b>	<b>SE, GI</b>
<b>168</b>	<b>90</b>	<b>Thermal Overload Trip</b>	<b>1</b>	<b>SE, GI</b>
168	91	Thermal Capacity Alarm	1	SE, GI
168	92	Load Increase Alarm	1	SE, GI
168	93	Thermal Overload Alarm	1	SE, GI
168	94	Phase A CT Failed	1	SE, GI
168	95	Phase B CT Failed	1	SE, GI
168	96	Phase C CT Failed	1	SE
<b>168</b>	<b>97</b>	<b>CT Failed</b>	<b>1</b>	<b>SE</b>
<b>168</b>	<b>98</b>	<b>Successful Close</b>	<b>1</b>	<b>SE, GI</b>
<b>168</b>	<b>100</b>	<b>Cold Load Pickup</b>	<b>2</b>	<b>SE, GI</b>
<b>168</b>	<b>101</b>	<b>Cold Load Trip</b>	<b>2</b>	<b>SE</b>
168	102	Line check trip	2	SE
168	103	Live Line	2	SE, GI
168	104	Live Bus	2	SE, GI
168	105	In Sync	2	SE, GI
168	106	External trip block	1	SE, GI
168	107	System Split	2	SE, GI
<b>168</b>	<b>110</b>	<b>E/Fm-Forward</b>	<b>2</b>	<b>SE, GI</b>
<b>168</b>	<b>111</b>	<b>E/Fm-Reverse</b>	<b>2</b>	<b>SE, GI</b>
168	112	V2 Element 1 Starter	2	SE, GI
168	113	V2 Element 2 Starter	2	SE, GI
168	114	V2 Element 1 Trip	2	SE, GI
168	115	V2 Element 2 Trip	2	SE, GI
168	116	F Element 1 Starter	2	SE, GI
168	117	F Element 2 Starter	2	SE, GI
168	118	F Element 3 Starter	2	SE, GI
168	119	F Element 4 Starter	2	SE, GI
168	120	F Element 1 Trip	2	SE, GI
168	121	F Element 2 Trip	2	SE, GI
168	122	F Element 3 Trip	2	SE, GI
168	123	F Element 4 Trip	2	SE, GI
168	135	VT Failed	2	SE, GI
<b>168</b>	<b>171</b>	<b>LS Trip</b>	<b>2</b>	<b>SE</b>
<b>168</b>	<b>172</b>	<b>Delayed Trip</b>	<b>2</b>	<b>SE</b>

Function	Information Number	Description	Function Type	Cause of Transmission
168	173	<b>HS1 Trip</b>	2	<b>SE</b>
168	174	<b>HS2 Trip</b>	2	<b>SE</b>
168	175	<b>Settings Group 5 Select</b>	1	<b>SE, GI</b>
			20	<b>Ack, Nak</b>
168	176	<b>Settings Group 6 Select</b>	1	<b>SE, GI</b>
			20	<b>Ack, Nak</b>
168	177	<b>Settings Group 7 Select</b>	1	<b>SE, GI</b>
			20	<b>Ack, Nak</b>
168	178	<b>Settings Group 8 Select</b>	1	<b>SE, GI</b>
			20	<b>Ack, Nak</b>
168	179	Trip count reset	1	SE
			20	Ack, Nak
168	180	Delta trip count reset	1	SE
			20	Ack, Nak
168	181	I <sup>2</sup> t count reset	1	SE
			20	Ack, Nak
168	182	<b>Remote Mode</b>	1	<b>SE, GI</b>
168	183	<b>Service Mode</b>	1	<b>SE, GI</b>
168	184	<b>Local Mode</b>	1	<b>SE, GI</b>
168	185	<b>3Vo Element 1 Starter</b>	2	<b>SE, GI</b>
168	186	<b>3Vo Element 2 Starter</b>	2	<b>SE, GI</b>
168	187	<b>3Vo Element 1 Trip</b>	2	<b>SE, GI</b>
168	188	<b>3Vo Element 2 Trip</b>	2	<b>SE, GI</b>
168	201	<b>3PAvEnergy</b>	4	<b>Cyclic</b>
168	202	<b>3PReacEnergy</b>	4	<b>Cyclic</b>
168	238	P/F Idmtl on/off	1	SE
			20	Ack, Nak
168	239	E/F Idmtl on/off	1	SE
			20	Ack, Nak
168	240	P/F Lowset on/off	1	SE
			20	Ack, Nak
168	241	P/F Highset 1 on/off	1	SE
			20	Ack, Nak
168	242	P/F Highset 2 on/off	1	SE
			20	Ack, Nak
168	243	E/F Lowset on/off	1	SE
			20	Ack, Nak
168	244	E/F Highset 1 on/off	1	SE
			20	Ack, Nak
168	245	E/F Highset 2 on/off	1	SE
			20	Ack, Nak
168	246	SEF1 on/off	1	SE
			20	Ack, Nak
168	247	SEF2 on/off	1	SE
			20	Ack, Nak
168	248	Thermal O/L on/off	1	SE
			20	Ack, Nak
168	249	Broken Conductor on/off	1	SE
			20	Ack, Nak
168	250	Cold Load on/off	1	SE

Function	Information Number	Description	Function Type	Cause of Transmission
			20	Ack, Nak
168	251	CT Supervision on/off	1	SE
			20	Ack, Nak
168	252	Trip Cct Supervision on/off	1	SE
			20	Ack, Nak
<b>168</b>	<b>253</b>	<b>Cold Start</b>	<b>1</b>	<b>SE</b>
<b>168</b>	<b>254</b>	<b>Warm Start</b>	<b>1</b>	<b>SE</b>
<b>168</b>	<b>255</b>	<b>Re-Start</b>	<b>1</b>	<b>SE</b>
200	1	CB 1	1	SE, GI
			20	Ack, Nak
200	2	CB 2	1	SE, GI
			20	Ack, Nak
200	3	CB 3	1	SE, GI
			20	Ack, Nak
200	4	CB 4	1	SE, GI
			20	Ack, Nak
200	5	CB 5	1	SE, GI
			20	Ack, Nak
<b>200</b>	<b>21</b>	<b>Iso 1</b>	<b>1</b>	<b>SE, GI</b>
			<b>20</b>	<b>Ack, Nak</b>
<b>200</b>	<b>22</b>	<b>Iso 2</b>	<b>1</b>	<b>SE, GI</b>
			<b>20</b>	<b>Ack, Nak</b>
<b>200</b>	<b>23</b>	<b>Iso 3</b>	<b>1</b>	<b>SE, GI</b>
			<b>20</b>	<b>Ack, Nak</b>
200	24	Iso 4	1	SE, GI
			20	Ack, Nak
200	25	Iso 5	1	SE, GI
			20	Ack, Nak
200	41	Earth Switch 1	1	SE, GI
			20	Ack, Nak
200	42	Earth Switch 2	1	SE, GI
			20	Ack, Nak
200	43	Earth Switch 3	1	SE, GI
			20	Ack, Nak
200	44	Earth Switch 4	1	SE, GI
			20	Ack, Nak
200	45	Earth Switch 5	1	SE, GI
			20	Ack, Nak
200	101	Control Item 1	1	SE, GI
			20	Ack, Nak
200	102	Control Item 2	1	SE, GI
			20	Ack, Nak
200	103	Control Item 3	1	SE, GI
			20	Ack, Nak
200	104	Control Item 4	1	SE, GI
			20	Ack, Nak
200	105	Control Item 5	1	SE, GI
			20	Ack, Nak
200	121	CB 1 Service Position	1	SE, GI
200	122	CB 2 Service Position	1	SE, GI

Function	Information Number	Description	Function Type	Cause of Transmission
200	123	CB 3 Service Position	1	SE, GI
200	124	CB 4 Service Position	1	SE, GI
200	125	CB 5 Service Position	1	SE, GI
200	255	Blocked By Interlocking	1	SE, GI
255	0	Time Synchronisation	6	Time Synchronisation
255	0	End of GI	8	End of GI

**Measurand**

Function	Information Number	Description	Function Type	Cause of Transmission
160	148	Measurand $I_{L1,2,3}$ , $V_{L1,2,3}$ , $P$ , $Q$ , $F$	9	Cyclic
168	200	Measurand $I_{L1,2,3}$ , $V_{L1,2,3}$ , $V_{L1-2, L2-3, L3-1}$ , $P$ , $Q$ , $F$ , Sync Angle	9	Cyclic

## Section 4: Modbus Definitions

### Coils (Read Write Binary values)

Address	Description
00001	Plant Control Relay 1
00002	Plant Control Relay 2
00003	Plant Control Relay 3
00004	Plant Control Relay 4
00005	Plant Control Relay 5
00006	Plant Control Relay 6
00007	Plant Control Relay 7
00008	Plant Control Relay 8
00009	Plant Control Relay 9
00010	Plant Control Relay 10
00011	Plant Control Relay 11
00012	Plant Control Relay 12
00013	Plant Control Relay 13
00014	Plant Control Relay 14
00015	Plant Control Relay 15
00016	Plant Control Relay 16
00017	Plant Control Relay 17
00018	Plant Control Relay 18
00019	Plant Control Relay 19
00020	Plant Control Relay 20
00021	Plant Control Relay 21
00022	Plant Control Relay 22
00023	Plant Control Relay 23
00024	Plant Control Relay 24
00025	Plant Control Relay 25
00026	Plant Control Relay 26
00027	Plant Control Relay 27
00028	Plant Control Relay 28
00029	Plant Control Relay 29
00030	Plant Control Relay 30
00031	Plant Control Relay 31
00032	Plant Control Relay 32
00100	LED Reset (Write only location)
00101	Settings Group 1
00102	Settings Group 2
00103	Settings Group 3
00104	Settings Group 4
00105	Settings Group 5
00106	Settings Group 6
00107	Settings Group 7
00108	Settings Group 8

### Inputs (Read Only Binary values)

10001	Status Input 1
10002	Status Input 2
10003	Status Input 3
10004	Status Input 4
10005	Status Input 5
10006	Status Input 6
10007	Status Input 7
10008	Status Input 8
10009	Status Input 9
10010	Status Input 10
10011	Status Input 11
10012	Status Input 12

10013	Status Input 13
10014	Status Input 14
10015	Status Input 15
10016	Status Input 16
10017	Status Input 17
10018	Status Input 18
10019	Status Input 19
10020	Status Input 20
10021	Status Input 21
10022	Status Input 22
10023	Status Input 23
10024	Status Input 24
10025	Status Input 25
10026	Status Input 26
10027	Status Input 27
10028	Status Input 28
10029	Status Input 29
10030	Status Input 30
10031	Status Input 31
10032	Status Input 32
10101	Front Port Override
10102	Remote mode
10103	Service mode
10104	Local mode
10111	Trip Circuit Fail
10112	A-Starter
10113	B-Starter
10114	C-Starter
10115	General Starter
10116	VTS Alarm
10122	P/F Char
10123	P/F LS
10124	P/F HS1
10125	P/F HS2
10126	E/F Char
10127	E/F LS
10128	E/F HS1
10129	E/F HS2
10130	E/Fm Char
10131	E/Fm LS
10132	E/Fm HS1
10133	E/Fm HS2
10134	SEF/REF 1
10135	SEF/REF 2
10145	CB Fail 1
10146	CB Fail 2
10148	Thermal Trip
10149	CTS Alarm
10150	I2-1
10151	I2-2
10152	V2-1
10153	V2-2
10154	Broken Conductor
10155	V-1
10156	V-2
10157	V-3
10158	V-4
10159	3V0-1
10160	3V0-2
10161	F-1
10162	F-2
10163	F-3
	F-4

## Registers

Address	Name	Format	Description
30001	No.of Events In Store	1 Register	
30002	Latest Event Record	8 Registers	
30010	Vab Primary	FP_32BITS_3DP <sup>1</sup>	Vab kV
30012	Vbc Primary	FP_32BITS_3DP <sup>1</sup>	Vbc kV
30014	Vca Primary	FP_32BITS_3DP <sup>1</sup>	Vca kV
30016	Phase A Primary Volt	FP_32BITS_3DP <sup>1</sup>	Va kV
30018	Phase B Primary Volt	FP_32BITS_3DP <sup>1</sup>	Vb kV
30020	Phase C Primary Volt	FP_32BITS_3DP <sup>1</sup>	Vc kV
30022	Phase a Secondary Volt	FP_32BITS_3DP <sup>1</sup>	Va V
30024	Phase b Secondary Volt	FP_32BITS_3DP <sup>1</sup>	Vb V
30026	Phase c Secondary Volt	FP_32BITS_3DP <sup>1</sup>	Vc V
30048	V0 RMS	FP_32BITS_3DP <sup>1</sup>	Vzps xVnom
30050	V1 RMS	FP_32BITS_3DP <sup>1</sup>	Vpps xVnom
30052	V2 RMS	FP_32BITS_3DP <sup>1</sup>	Vnps xVnom
30060	Frequency	FP_32BITS_3DP <sup>1</sup>	Hz
30064	Phase A Primary Curr	FP_32BITS_3DP <sup>1</sup>	Ia kA
30066	Phase B Primary Curr	FP_32BITS_3DP <sup>1</sup>	Ib kA
30068	Phase C Primary Curr	FP_32BITS_3DP <sup>1</sup>	Ic kA
30070	Phase a Secondary Curr	FP_32BITS_3DP <sup>1</sup>	Ia A
30072	Phase b Secondary Curr	FP_32BITS_3DP <sup>1</sup>	Ib A
30074	Phase c Secondary Curr	FP_32BITS_3DP <sup>1</sup>	Ic A
30088	Earth Primary Curr	FP_32BITS_3DP <sup>1</sup>	In kA
30094	Aux Primary Curr	FP_32BITS_3DP <sup>1</sup>	Ig kA
30096	Aux Secondary Curr	FP_32BITS_3DP <sup>1</sup>	Ig A
30100	I0 RMS	FP_32BITS_3DP <sup>1</sup>	Izps xIn
30102	I1 RMS	FP_32BITS_3DP <sup>1</sup>	Ipps xIn
30104	I2 RMS	FP_32BITS_3DP <sup>1</sup>	Inps xIn
30118	3P P	FP_32BITS_3DP <sup>1</sup>	3 Phase MW
30126	3P RP	FP_32BITS_3DP <sup>1</sup>	3 Phase MVAr
30134	3P AP	FP_32BITS_3DP <sup>1</sup>	3 Phase MVA
30142	3P PF	FP_32BITS_3DP <sup>1</sup>	3 Phase
30144	Whr	FP_32BITS_3DP <sup>1</sup>	3 Phase MWh
30148	VArhr	FP_32BITS_3DP <sup>1</sup>	3 Phase MWh
30154	Thermal State	UINT16 <sup>2</sup>	%
30167	Waveform Records	UINT16 <sup>2</sup>	
30168	Event Records	UINT16 <sup>2</sup>	
30170	Vab Secondary Volt	FP_32BITS_3DP <sup>1</sup>	Vab V
30172	Vbc Secondary Volt	FP_32BITS_3DP <sup>1</sup>	Vbc V
30174	Vca Secondary Volt	FP_32BITS_3DP <sup>1</sup>	Vca V

1) FP\_32BITS\_3DP: 2 registers - 32 bit fixed point, a 32 bit integer containing a value to 3 decimal places e.g. 50000 sent = 50.000

2) UINT16: 1 register - standard 16 bit unsigned integer



## Section 5: Application Diagrams

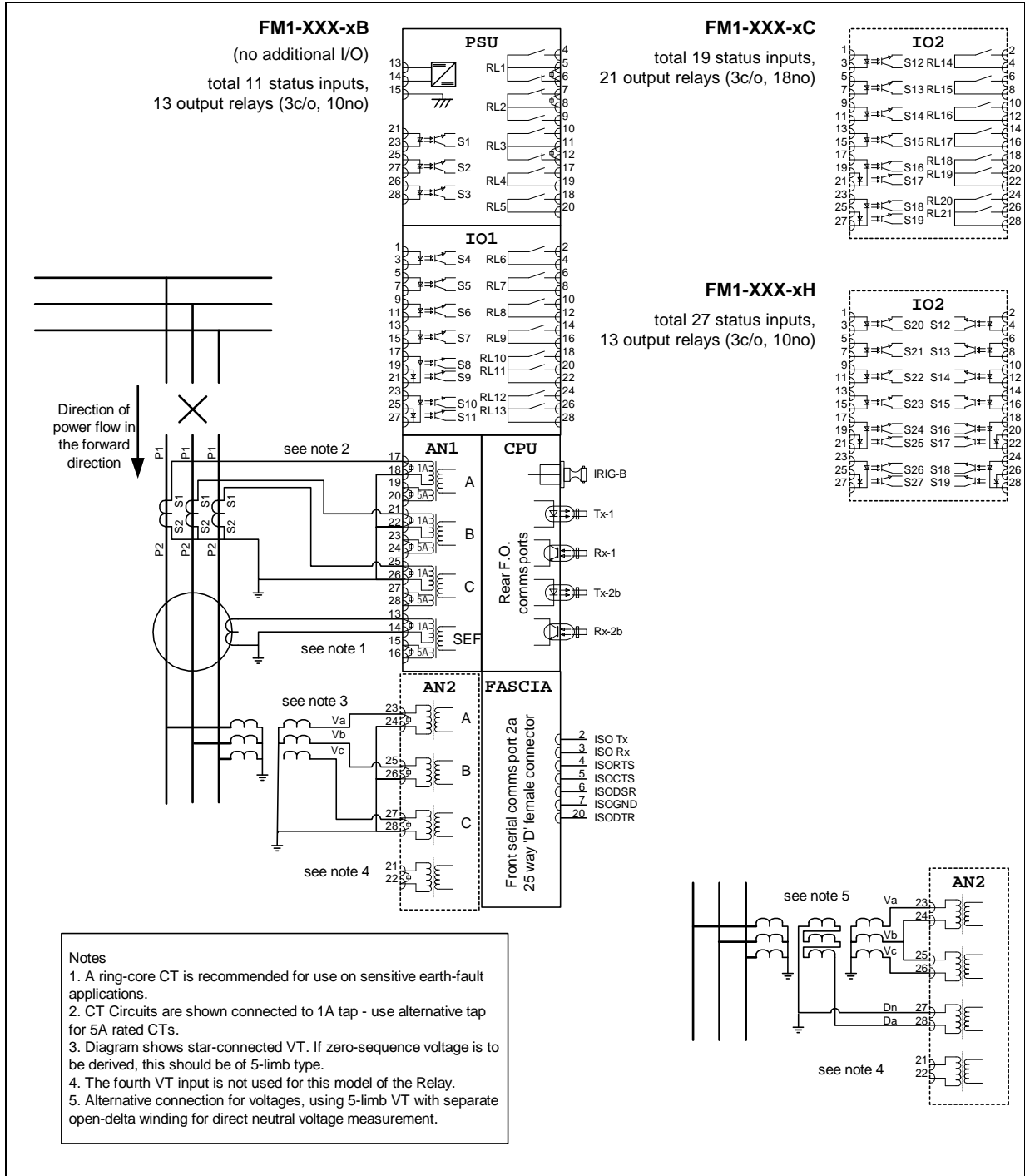

Figure 5-1 Typical Connection Diagram